



Damrongsilp
GROUP



SMART 400

THE SIMPLIFY COMFORT

2X2 seat Configuration,
Manual Reclining, Back Handle
Maximum Reclining 125 Degree



MANUFACTURING AND EXPORTING AUTOMOTIVE SEATS
AND ACCESSORIES FROM HIGH TECHNOLOGY EQUIPMENTS
AND INTERNATIONAL STANDARD QUALITY

AUTOMOTIVE SEAT LEADER

AUTOMOTIVE SEAT LEADER

SMART 400 : Specification



Options :

Upholstery	Genuine Leather/Fabric/PVC
Leg Support	Manual Type
Armrest	Single/Double/Triple
Seatbelt	2 Points Manual/Auto or 3 Points Auto
Handle	At the back
Monitor	7"-10" At the back (Without Handle)
Cup Holder	At the back
Magazine net	At the back
Footrest	Manual Type
Massager	Vibration Type/Air Type
Foodtray	At armrest
USB Charger	12V/24V Enable
Side Slide	50 mm. (Without Leg Support)
Leg Mounting	Single Leg with bracket/Double Leg

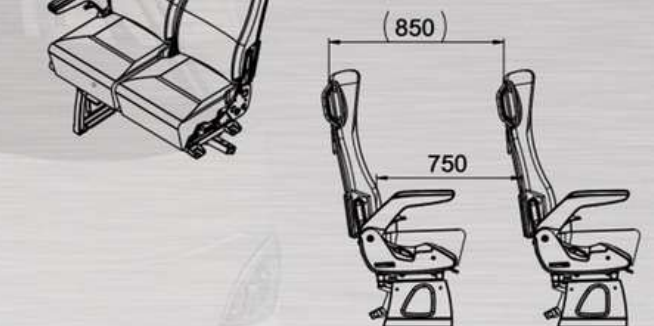
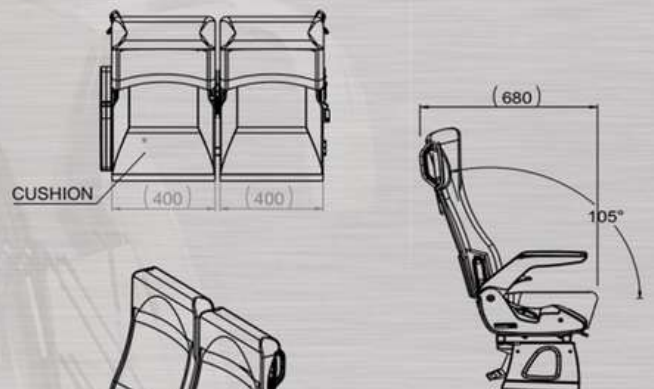
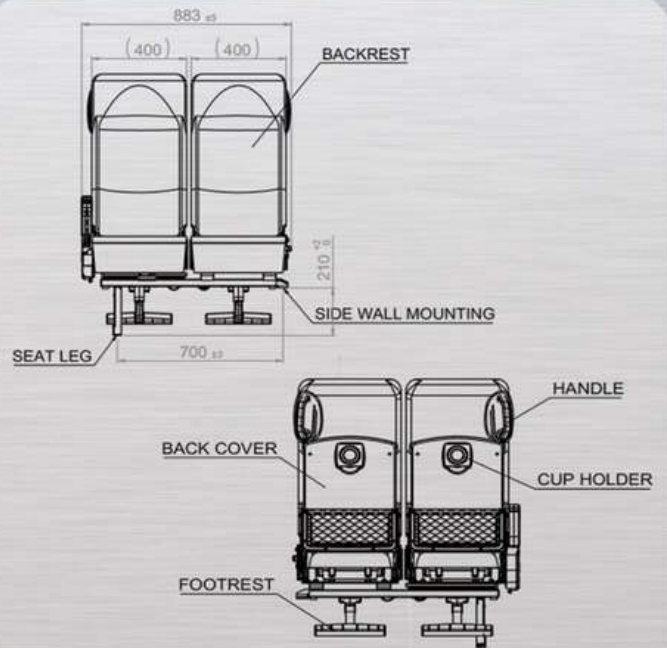

Using the very latest,
highly automated
manufacturing systems.

DAMRONGSILP GROUP

95 Moo 1 Malaiman Rd., Tungcok, Songpheenong Suphanburi 72110 Thailand
Tel. +66 0 3547 3873-4 Fax. +66 0 3554 1269, +66 0 3546 2852

<http://www.facebook.com/damrongsilpgroup>

Website : <http://www.damrongsilp.co.th> Email : info@damrongsilp.co.th

